

## STANDARD OPERATING PROCEDURE Procedure for Zooplankton Sample Collection

**Compiled By -**

**Name:** Donald Reid and Mary Balcer

**Title:** GSI Land-Based RDTE Facility Biological Operations Specialist and GSI Senior Zooplankton Scientist

**Date:** July 20, 2009

**Approved By -**

**Name:** Nicole Mays

**Title:** GSI Senior QAQC Officer

**Date:** July 20, 2009

**Cleared For Issue By -**

**Name:** Allegra Cangelosi

**Title:** GSI Principal Investigator

**Date:** July 20, 2009

**RECORD OF AMENDMENTS:**

**No.   Date                      Type**

**No.   Date                      Type**

1. \_\_\_\_\_

7. \_\_\_\_\_

2. \_\_\_\_\_

8. \_\_\_\_\_

3. \_\_\_\_\_

9. \_\_\_\_\_

4. \_\_\_\_\_

10. \_\_\_\_\_

5. \_\_\_\_\_

11. \_\_\_\_\_

6. \_\_\_\_\_

12. \_\_\_\_\_

## STANDARD OPERATING PROCEDURE

### Procedure for Zooplankton Sample Collection

#### BACKGROUND

The [Great Ships Initiative](#) (GSI) is a collaborative effort to end the problem of ship-mediated invasive species in the Great Lakes-St. Lawrence Seaway System through independent research and demonstration of environmental technology, financial incentives and consistent basin-wide harbor monitoring. To that end, GSI has established research capabilities at three scales—bench, land-based, and shipboard. Each scale is dedicated to addressing specific evaluation objectives, with protocols as consistent with IMO and federal requirements as practicable. Developers of ballast treatment systems apply for GSI research services [online](#), and awards are offered based on an objective review process. GSI incubation/testing will allow meritorious ballast treatment systems to progress as rapidly as possible to an approval-ready and market-ready condition.

The GSI's Land-Based Research, Development and Technology Evaluation (RDTE) Facility in Superior, Wisconsin is used to conduct full-scale biological evaluations of prospective ballast treatments suitable to Seaway-sized vessels. The facility draws raw intake water and entrained organisms from Duluth-Superior Harbor at up to 680 m<sup>3</sup>/hr. After initial transport through 16 inch HDPE line to the facility, a carefully designed “Y-split” in the intake piping simultaneously channels one half of the flow (up to 340 m<sup>3</sup>/hr) to a treatment track and one half (up to 340 m<sup>3</sup>/hr) to a matched control track (figure 1). Water in the treatment track passes through the experimental ballast treatment system and into one of the 200 m<sup>3</sup> cylindrical treatment retention tanks (test tank #1 or #2; figure 1). Water in the control track by-passes the treatment system and is channeled directly into a matched control retention tank (control tank #1 or #2; figure 1). After storage (duration dependent on test requirements), the water is discharged sequentially from the treatment and control retention tanks at up to 340 m<sup>3</sup>/hr. Depending on the test scenario, the water is either discharged to the harbor or sewer system, into an alternate retention tank, or through the treatment system again for discharge or retention.

Treatment and control intake and discharge water is sampled at pressure/flow controlled in-line sample points (SPs). Intake samples are collected concurrently on the control and treatment tracks respectively (using SP2 and SP3, figure 2). Post-treatment samples are collected from SP15 (figure 2). Discharge samples are collected from one of two discharge sample points (SP9, or SP10; figure 2), with sequential sampling of control and treatment water. At each of these SPs there are three replicate sample ports with a center-located 3.8 cm internal diameter (ID) elbow-shaped pitot tube (figure 3) connected to a 3.8 cm ID PVC transfer pipe that carries the sample water to one of six collection tubs located at a centralized sampling station (figure 2). Other SPs shown on figure 5, with one port per SP, are used for calibration testing the facility itself and not typically used for sample collection during a treatment system evaluation.

A mobile field laboratory provides bench-scale facilities to support time-sensitive assays associated with tests conducted at the GSI Land-Based RDTE Facility. The laboratory is located

at the facility during testing but may be moved to other sites in the Great Lakes-St. Lawrence Seaway System to support GSI shipboard tests when required. It is climate-controlled, and has enough desk and counter space to allow for simultaneous microscopic and analytical analysis of zooplankton, phytoplankton and bacteria samples. In addition, laboratories of the University of Wisconsin-Superior's Lake Superior Research Institute (LSRI) and the University of Minnesota-Duluth's Natural Resources Research Institute provide non-time sensitive analysis of samples from the land-based tests. Since both facilities are only a few miles from the facility, samples can be easily transported for rapid analysis.

**Figure 1. Simplified Schematic of the GSI Land-Based RDTE Facility.**

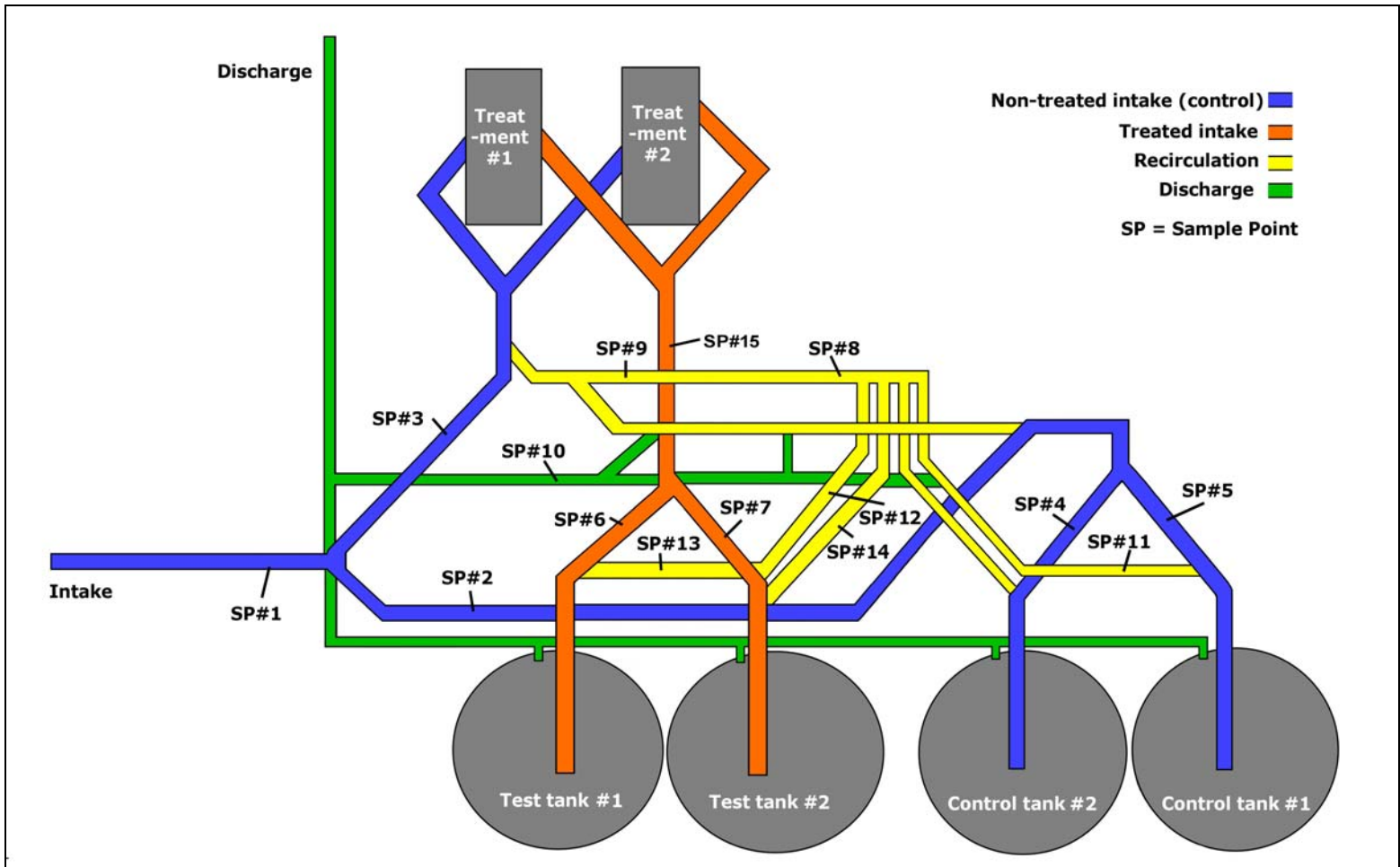

**Figure 2. Schematic of the GSI Land-Based RDTE Facility Showing the Location of the Intake and Discharge Sample Points (SPs), Sample Ports, and Corresponding Sample Collection Tubs.**

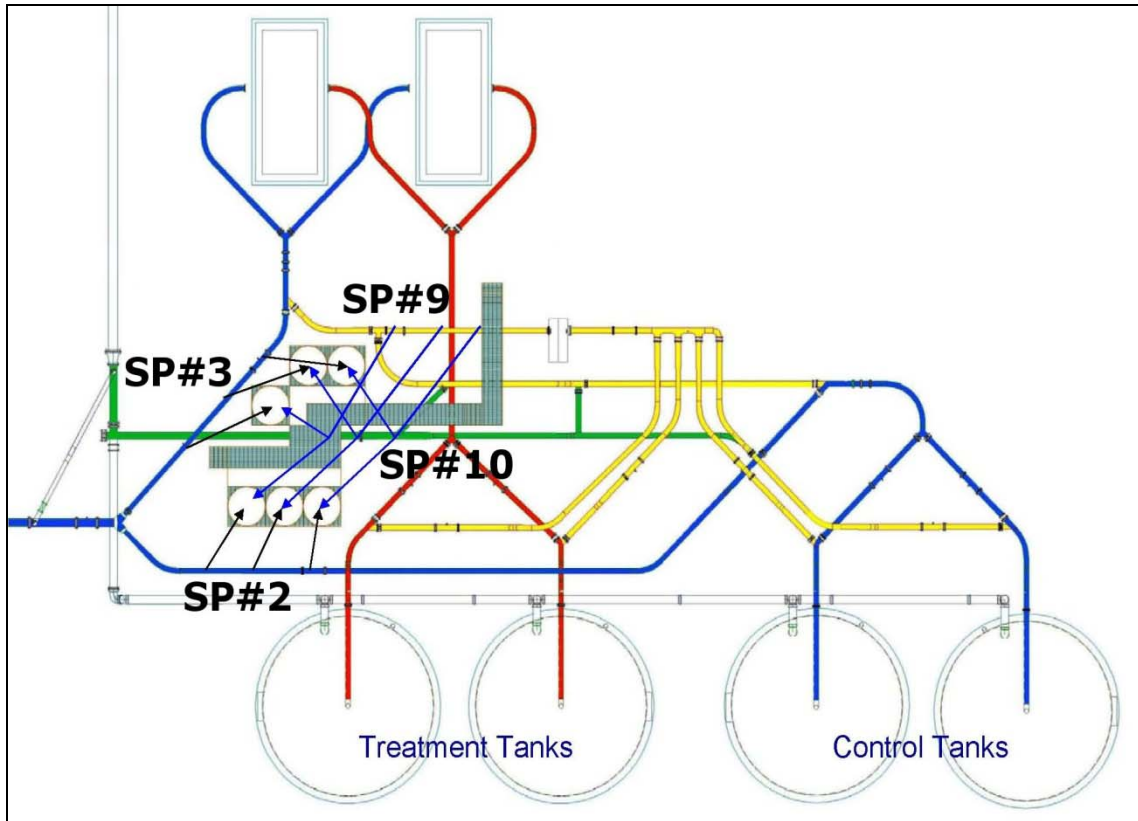

**Figure 3. Schematic of a Sample Point (SP) Showing the Design of the Three Sample Port Pitots.**

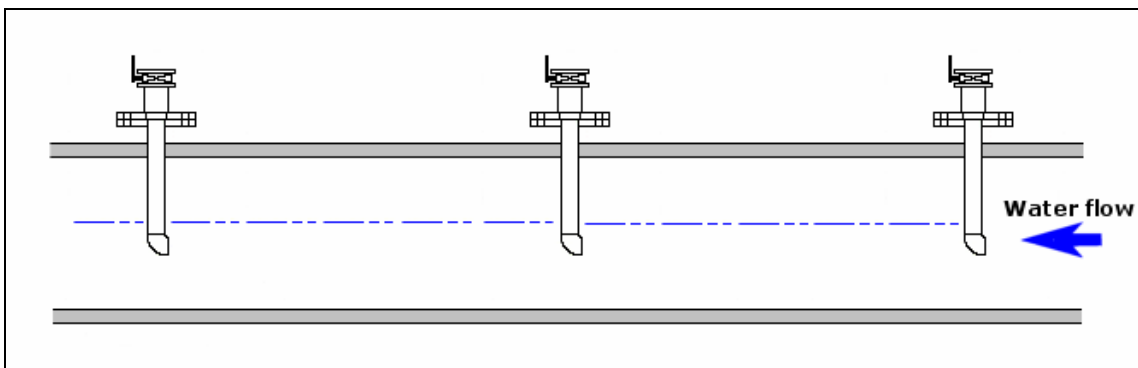

## INTRODUCTION

This GSI Standard Operating Procedure (SOP) describes collection of zooplankton samples at the GSI Land-Based RDTE Facility. Based on IMO criteria, this category refers to organisms equal to or greater than 50  $\mu\text{m}$  in minimum dimension, typically dominated by rotifers, copepod nauplii, cladocerans, copepod copepodites, and other macrozooplankton.

## EQUIPMENT LIST

- Six 3.8 m<sup>3</sup> sample collection tubs with attached yardsticks, plankton net hooks and flexible 3.8 cm ID drainspout hose with quick-connect fittings.
- One 3.0 m<sup>3</sup> stripping tank with attached yardstick, plankton net hook and removable flexible 3.8 cm ID drainspout hose with quick-connect fittings.
- Two 130 Liter plastic barrels with 2.5 cm and 3.8 cm bottom drains to serve as plankton net support reservoirs, one for use at the sample collection tub station, one for use at the stripping tank sampling station.
- At least six 1 Liter plastic sample bottles.
- Three 4 Liter plastic containers.
- Three 10 Liter plastic containers.
- Three 20 Liter plastic containers.
- Four plankton nets (30 cm diameter mouth; 90 cm length; 20  $\mu\text{m}$  mesh) with 1 Liter cod ends.
- Extra 1 Liter cod-ends.
- Protective eyeglasses/goggles and gloves (if a chemical treatment is to be tested).
- Colored tape (various colors).
- Preprinted sample bottle labels.
- One clipboard, preprinted data sheet and pen for each sampling event.
- One field notebook.
- Cooler (for storage and transport).

## PROCEDURE

### Preparation

1. Ensure that all sampling equipment including plankton nets, cod ends and drainspout hoses is clean prior to use (see *GSI/SOP/LB/G/O/3 - Procedure for Cleaning the Retention Tanks and Other Equipment at the GSI Land-Based RDTE Facility*).
2. Clean and label at least 6 1-Liter sample bottles as “filtered water”.
3. Prepare all data recording sheets and attach to clipboards.

## Sample Collection

1. Place a drainable 130 Liter plastic barrel under each collection tub drainspout following collection of algae/small protozoa and microbial samples (see *GSI/SOP/LB/RA/SC/1 – Procedure for Collecting Biological Water Samples Via In-Line Sample Ports*, *GSI/SOP/LB/RA/SC/3 - Procedure for Algae/Small Protozoa Sample Collection*, and *GSI/SOP/LB/RA/SC/4 - Procedure for Microbial Sample Collection*).
2. Attach the 3.8 cm in ID drainspout hose to the drainspout
3. Suspend a plankton net from the net hook so that it is hanging in the plastic bucket with the drain hose positioned to direct water from the sample collection tub/stripping tank into the cod-end of the plankton net.
4. Record the water height from each tub's yardstick and the water volume from the engineer's operational data on the data sheet.

## Collecting Samples While Draining the Sample Collection Tubs/Stripping Tank

1. In sequence, open each collection and stripping tub drain valve and filter the entire volume of water retained in the collection tub through the plankton net. As the collection tub water is filtered, filtrate water will collect in the 130 Liter plastic barrel.
2. Collect filtrate from the barrel outside of the plankton net in at least 6 1 Liter bottles. Partially fill, swirl and empty each bottle twice with the lid held loosely in place, then fill a third time, attach lid and store in the cooler.
3. When the collection tub has drained, remove the plankton net from its hook, drift it back and forth twice in the reservoir, and then raise and lower it to help wash organisms down the inside of the net and into the cod-end.
4. Hold the plankton net upright and lift it from the barrel. Move to a location where the cod-end can be placed on a flat surface. Carefully push the lower part of the net into the cod-end using the extended fingers of both hands. This action displaces water but not organisms from the cod-end, preventing sample spillage when the cod end is removed from the net.
5. Gently pull the lower part of the net out of the cod-end. Remove the cod-end from the plankton net, cap it with the appropriately labeled lid and place in a cooler.
6. If the sample is very concentrated, gently pour the sample into a larger collection container and add filtrate water as needed to ensure that the density of plankton in the container is no greater than 10,000X ambient density or 1,000,000 organisms per liter of concentrate. In general, the 1-Liter cod end containers are suitable for plankton samples that have been filtered from up to 2 m<sup>3</sup> of water, 4-Liter containers can be used for

samples filtered from 3 - 4 m<sup>3</sup> of water, 10-Liter containers for samples from up to 10 m<sup>3</sup> of water, and 20-Liter containers for larger volumes.

7. Record sample collection time and other pertinent information on the field data sheet.
8. Transfer the cooler containing the zooplankton samples to the on-site mobile laboratory for immediate analysis (see *GSI/SOP/LB/RA/SC/2 – Procedure for Zooplankton Sample Collection*).

### **Sample Collection Sequence**

1. Determine the order of sample collection and then drain the collection tubs one at a time. After control and treatment tanks are filled, samples should be drained from the post-treatment tub (SP15- tub 6), treatment fill tub (SP3- tub 4) and then the control fill tub (SP2- tub 1). When the tanks are drained, the Treatment tank should be drained first and samples should be collected (SP9 A, B, and C prior to draining the Control tank and collecting those samples (SP9 A, B, and C)
2. Adjust the drain valves of the 130 Liter plastic barrel when collecting water to ensure that the plankton net is still supported, but sample water does not spill over the top of the bucket.
3. Time the collection of subsequent samples to coincide with the zooplankton analysis team's readiness to commence processing.

### **QUALITY ASSURANCE/QUALITY CONTROL (QA/QC)**

1. Conduct all quality assurance/quality control procedures according to the GSI/QAPP/1 - Quality Assurance Project Plan (QAPP) for Great Ships Initiative Bench-Scale and Land-Based Biological Tests (2009).
2. Follow all procedures outlined in this SOP. Any deviations known ahead of time must be approved by the GSI Principal Investigator or one of the two Lead On-Site Investigators. Any deviations made during the experiment must be recorded and also approved by the GSI Principal Investigator or one of the two Lead On-Site Investigators as soon as practicable.
3. Ensure a second individual checks the log book and data sheets for completeness following each collection event. Provide copies of the daily log to the Quality Assurance Manager at the end of the sampling day along with the sample collection records.

### **DATA STORAGE AND ARCHIVING**

1. Store and archive data according to GSI/QAPP/1 - Quality Assurance Project Plan (QAPP) for Great Ships Initiative Bench-Scale and Land-Based Biological Tests (2009).

2. Archive all hard- and electronic-copies of data and records generated for a period of five years.

## REFERENCES AND RELATED DOCUMENTS

Cangelosi AA (2006). RDTE Facility for the Great Ships Initiative (GSI) (OAR-SG-2006-20000364). Project Proposal to the National Oceanic and Atmospheric Administration/U.S. Fish and Wildlife Service. Northeast-Midwest Institute, Washington D.C.

Eaton AD, Clesceri LS, Rice EW & Greenberg AE, Eds. (2005). Standard Methods for the Examination of Water & Wastewater.

Great Ships Initiative website: [www.greatshipsinitiative.org](http://www.greatshipsinitiative.org).

Great Ships Initiative Standard Operating Protocols: <http://www.nemw.org/GSI/protocols.htm>.

GSI/QAPP/1 - Quality Assurance Project Plan for Great Ships Initiative (GSI) Bench-Scale and Land-Based Biological Tests (2009).

GSI/SOP/G/RA/SC/2 – Procedure for Labeling Samples Collected at the GSI Land-Based RDTE Facility

GSI/SOP/LB/G/O/1 – Procedure for Operating the GSI Land-Based RDTE Facility.

GSI/SOP/LB/G/O/3 - Procedure for Cleaning the Retention Tanks and Other Equipment at the GSI Land-Based RDTE Facility.

GSI/SOP/LB/RA/SC/1 – Procedure for Collecting Biological Water Samples via In-Line Sample Ports.

GSI/SOP/LB/RA/SC/3 - Procedure for Algae/Small Protozoa Sample Collection.

GSI/SOP/LB/RA/SC/4 - Procedure for Microbial Sample Collection.

GSI/SOP/LB/RA/SC/6 – Procedure for Zooplankton Sample Collection.

GSI/SOP/LB/RA/SC/7 – Procedure for Preparing Lugol's Solution.

GSI/SOP/LB/RA/SA/2 – Procedure for Zooplankton Sample Analysis.